

CONVEYOR & BULKHEAD LIGHTS



HUNTER



CONVEYOR & BULKHEAD LIGHTS

HUNTER

The Hunter is the perfect solution for Conveyor, Walkway and Platform Lighting as it is available in either a polyester powder-coated aluminium body or a 316 stainless steel body. These options make it suitable for areas in high corrosion such as Coal Washeries, Materials Handling and Industrial Processing Plants.



TYPICAL APPLICATIONS



Mining, MIA (Mining Infrastructure Area), Coal, Open Cuts, Metalliferous, Iron Ore, Industrial, Processing Plants, Materials Handling, Lithium Processing, Power Generation, Energy & Utilities, Water & Waste Water, Ports, Wharfs & Waterways, Chemical & Processing

SPECIFICATIONS

Model	PLIHTR48
Optical Characteristics	
Rated Wattage	48W
Lumens	5520
System Efficacy	115Lm/W
Colour Temperature CCT	3000K (5000K / 4000K / Green Eyewash)
CRI (Ra)	>80
Reported L70	>50,000 Hours
Lens Optic Type	Type II
Electrical Characteristics	
Input	AC90-240V
Frequency	50Hz
Powerfactor	>0.95
Total Harmonic Distortion	<9%
Environment	
IP Rating	IP66
Impact Rating	IK10
Operating Temperature	-25°C To 40°C
Product Material and Mounting	
Mounting	Suits 34mm Spigot
Product Material	Aluminum or Stainless Steel Housing
Lens / Optics Material	PMMA
Dimensions and Weights	
Product Dimensions	382*184*204
Product Weight	4.7KG
Packaging Dimensions (Ctn 6)	435*705*430
Gross Weight (Ctn 6)	28.2KG
Warranty and Certifications	
Warranty	5 Year Warranty
Certifications	CE / RoHS

CONVEYOR & BULKHEAD LIGHTS

DIMENSIONS

Fixture

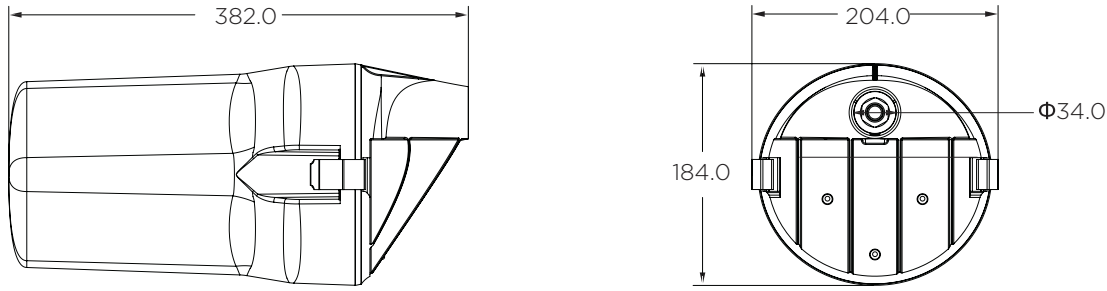

Remote Emergency Terminal Box

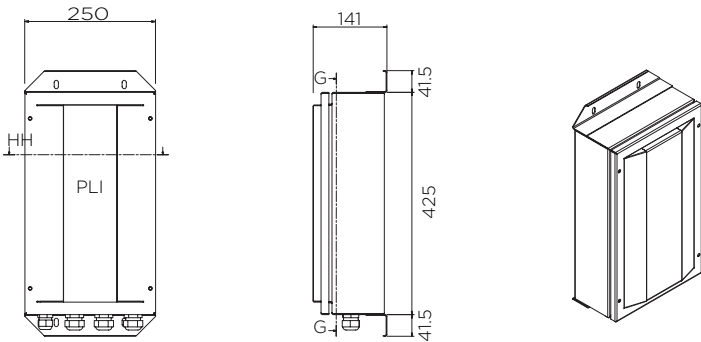

Green Eyewash Available

PHOTOMETRIC DIAGRAMS

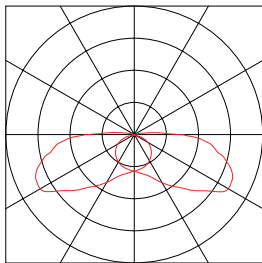

TYPE II

ORDERING METHODOLOGY

PLI-HTR

XX
WATTS
48

XX
CCT

- 50 (5000K)
- 40 (4000K)
- 30 (3000K)
- G (GREEN EYEWASH)

X
HOUSING

- S (STAINLESS STEEL)
- A (ALUMINUM)

XXXX
FUNCTION

- ST (STANDARD)
- R/HETB (REMOTE EMERGENCY)
- I (INTEGRATED EMERGENCY)

ACCESSORIES

HUNTER REMOTE EMERGENCY TERMINAL BOX

PLIHTR/HETB

CONVEYOR & BULKHEAD LIGHTS

