

LED BATTENS WEATHERPROOF



KESTREL

LED BATTENS WEATHERPROOF

KESTREL

The Kestrel is a high performance, corrosion resistant, IP65 waterproof batten. With GRP housing the Kestrel is designed to withstand aggressive atmospheres laden with salts, acids, and mineral oils. The Kestrel is suitable for locations that are exposed to liquids and gases that contain potentially corrosive chemicals.



TYPICAL APPLICATIONS



Mining, MIA (Mining Infrastructure Area), Coal, Open Cuts, Metalliferous, Iron Ore, Industrial, Processing Plants, Materials Handling, Lithium Processing, Power Generation, Energy & Utilities, Water & Waste Water, Ports, Wharfs & Waterways, Chemical & Processing

SPECIFICATIONS

Model No.	PLIKES15	PLIKES24	PLIKES20	PLIKES36	PLIKES50	PLIKES30	PLIKES50	PLIKES65
Optical Characteristics								
Rated Wattage	15W	24W	20W	36W	50W	30W	50W	65W
Lumens	1950	3120	2600	4680	6500	3900	6500	8450
System Efficacy	130Lm/W							
Colour Temperature CCT	5000K (6500K / 5700K / 4000K / 3000K)							
CRI (Ra)	>80							
Reported L70	>50,000 Hours							
Lens Optic Type	120°							
Electrical Characteristics								
Input	220-240V							
Frequency	50/60Hz							
Powerfactor	>0.95							
GWT	850°C							
Environment								
IP Rating	IP65							
Impact Rating	IK08							
Operating Temperature	-15°C To 35°C							
Product Material and Mounting								
Option 1	Bracket Mount							
Option 2	Suspension Chain							
Product Material	GRP Housing (Glass Reinforced Plastic)							
Lens / Optics Material	Corrosion Resistant PMMA Diffuser							
Dimensions and Weights								
Product Dimensions	600*116*100		1200*116*100			1500*116*100		
Product Weight	1.5KG		3.0KG			4.0KG		
Packaging Dimensions	630*268*232		1230*268*232			1530*268*232		
Gross Weight	2.0KG		3.5KG			4.5KG		
Warranty and Certifications								
Warranty	5 Year Warranty							
Certifications	SAA / CE / RoHS							

LED BATTENS WEATHERPROOF

DIMENSIONS

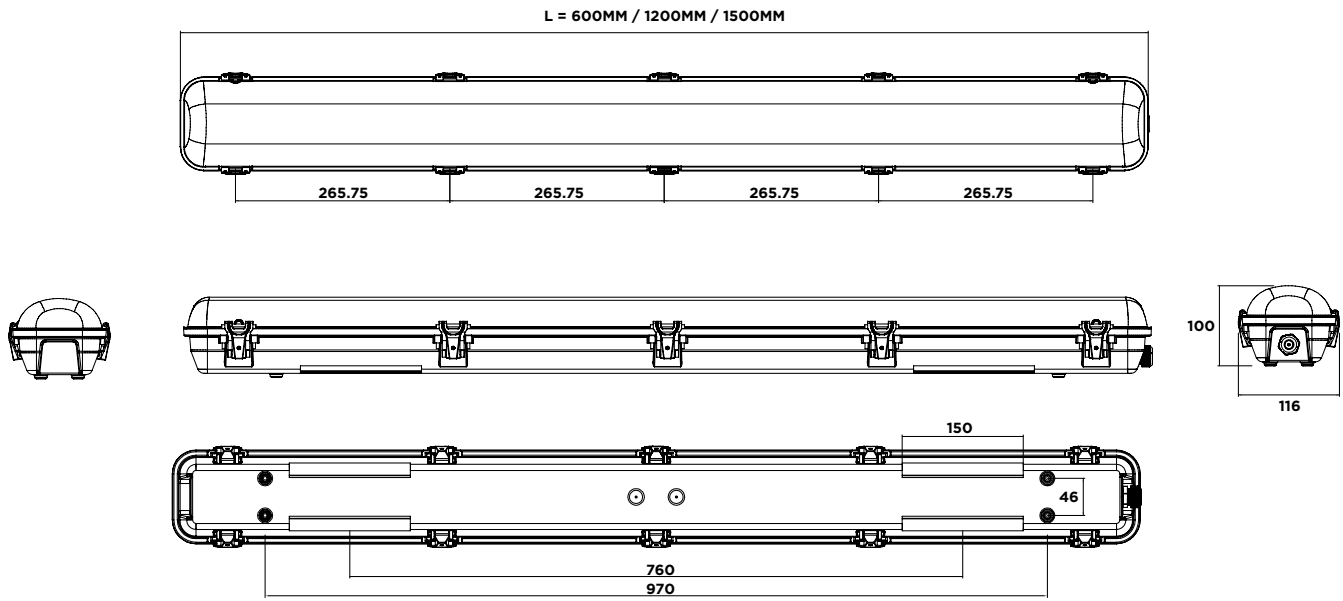

PHOTOMETRIC DIAGRAMS

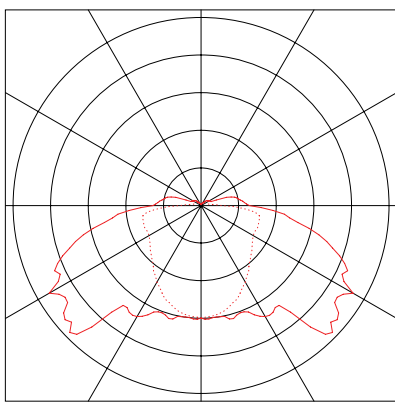

120°

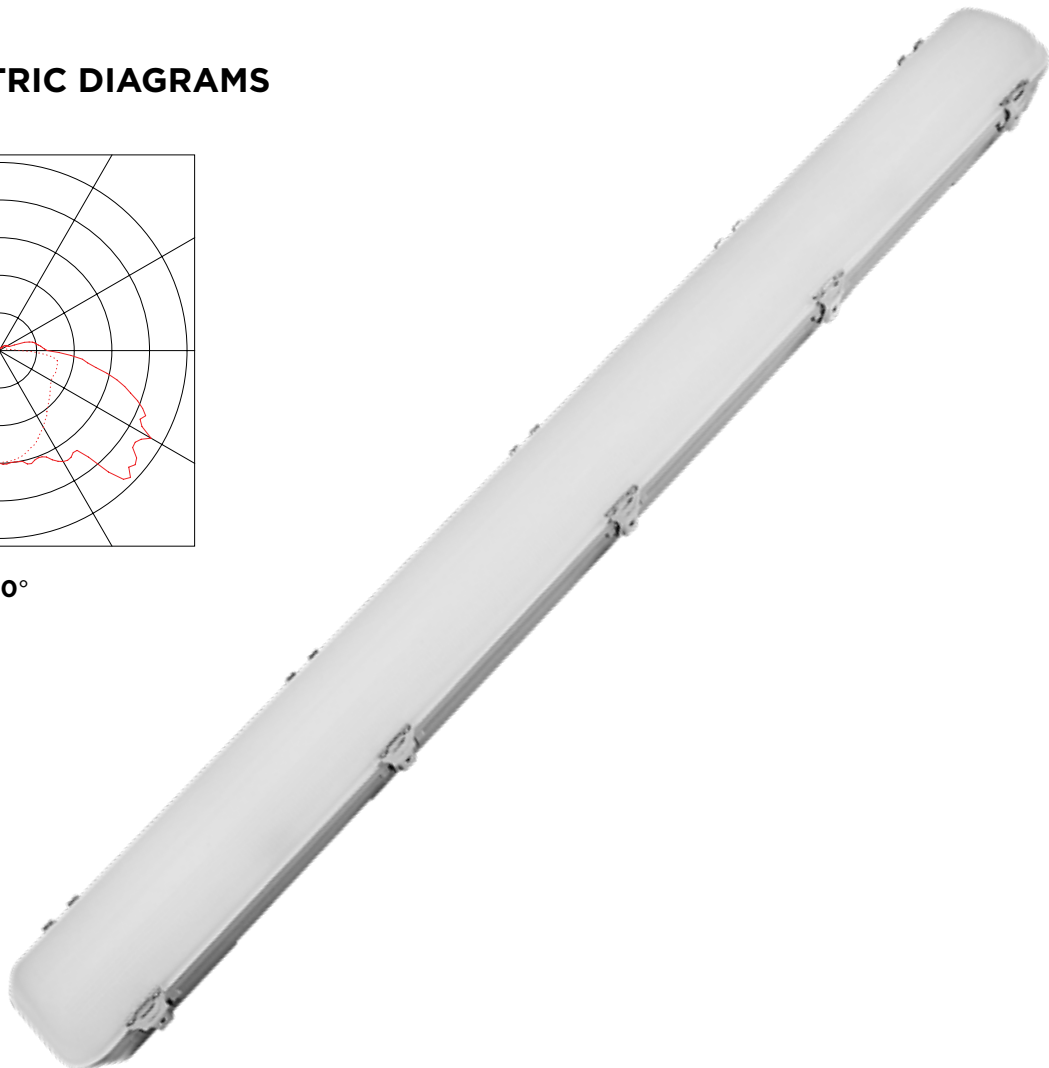

LED BATTENS WEATHERPROOF

ORDERING METHODOLOGY

PLI-KES	XX WATTS	XX CCT	XX DIMENSIONS
	15W	65 (6500K)	01 (50W/1200*116*100)
	20W	57 (5700K)	02 (50W/1500*116*100)
	24W	50 (5000K)	
	30W	40 (4000K)	
	36W	30 (3000K)	
	50W		
	65W		

ACCESSORIES

BRACKET MOUNT	PLIKES/BM
SUSPENSION CHAIN	PLIKES/SC

