

HIGH-POWER FLOODLIGHTS



**PHOENIX
PLUS**

HIGH-POWER FLOODLIGHTS

PHOENIX PLUS

The Phoenix Plus is a sleek and reliable compact floodlight with an efficiency of up to 135Lm/W. An excellent temperature range of -30°C to +50°C makes the Phoenix Plus a lighting solution suitable for a wide range of Industrial and Mining applications.



TYPICAL APPLICATIONS



Mining, MIA (Mining Infrastructure Area), Coal, Open Cuts, Metalliferous, Iron Ore, Industrial, Processing Plants, Materials Handling, Lithium Processing, Power Generation, Energy & Utilities, Water & Waste Water, Ports, Wharves & Waterways, Chemical & Processing, Ports & Wharves, Airports, Car Parks, General Area Lighting, Container Terminals

SPECIFICATIONS

Model:	PLIPHXP50	PLIPHXP100	PLIPHXP150	PLIPHXP200	PLIPHXP300
Optical Characteristics					
Rated Wattage	50W	100W	150W	200W	300W
Lumens	6750	13500	20250	27000	40500
System Efficacy	135Lm/W				
Colour TemperatureCCT	5000K (4000K / 3000K / 2200K Amber Turtle Friendly)				
CRI (Ra)	>70				
Reported L70	>50,000 Hours				
Lens Optic Type	30° x 60° / 65° x 120° / 65° x 120° FT / 15° / 30° / 60° / 90°				
Electrical Characteristics					
Input	100-240VAC				
Frequency	50Hz				
Powerfactor	>0.92				
Total Harmonic Distortion	10%				
Environment					
IP Rating	IP66				
Impact Rating	IK08				
Operating Temperature	-30°C To 50°C				
Product Material and Mounting					
Option 1	Trunion Bracket Mount				
Option 2	Pole Spigot Adaptor (42mm, 60mm, 76mm)				
Product Material	Aluminum Alloy				
Lens / Optics Material	Toughened Glass, PC Lens				
Dimensions and Weights					
Product Dimensions	314*240*63	418*330*77	451*330*77	494*395*87	567*465*97
Product Weight	2.6KG	3.9KG	4.5KG	6.3KG	9.5KG
Packaging Dimensions	364*280*105	474*368*120	516*368*130	568*430*140	652*510*160
Gross Weight	2.9KG	4.5KG	5.2KG	7.2KG	10.6KG
Warranty and Certifications					
Warranty	5 Year Warranty				
Certifications	CE / SAA / RoHS				

HIGH-POWER FLOODLIGHTS

DIMENSIONS

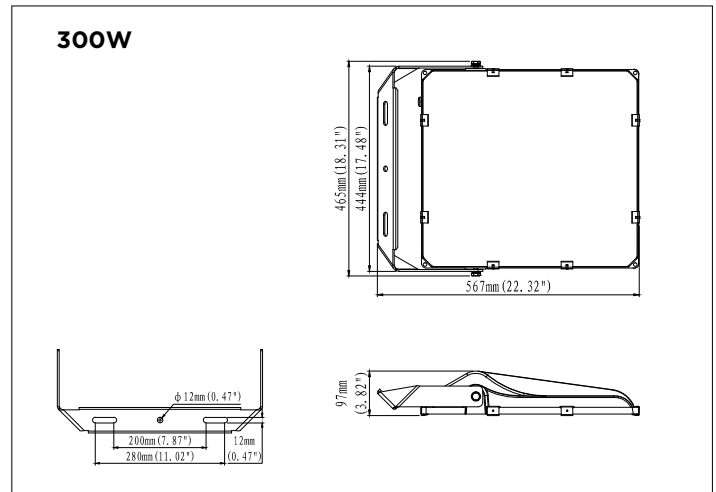
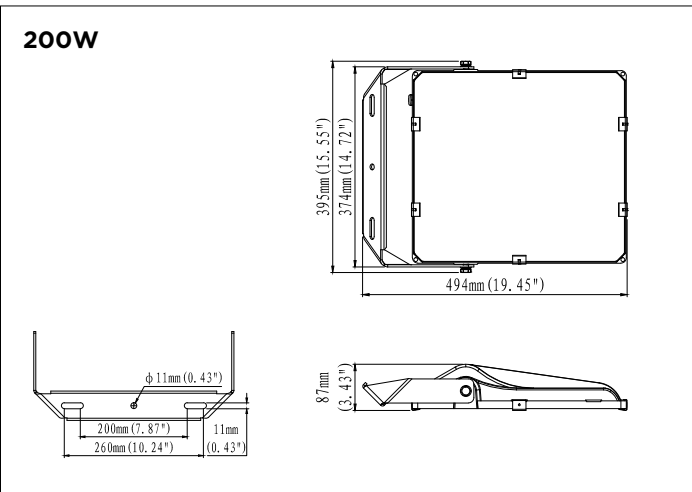
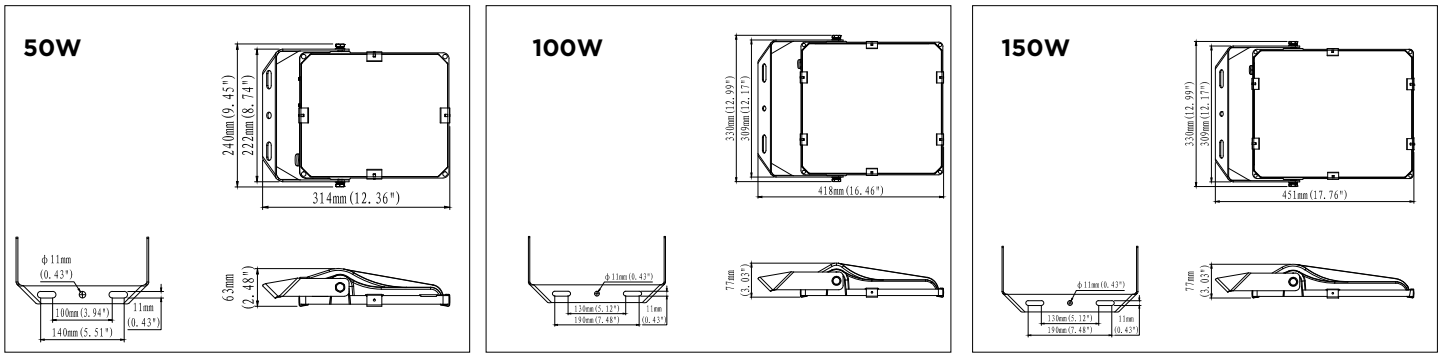

PHOTOMETRIC DIAGRAMS

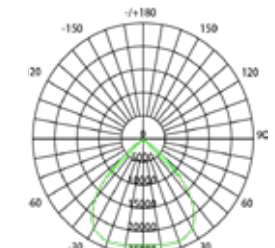
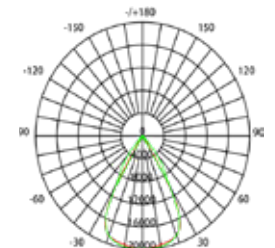
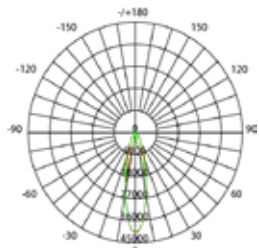
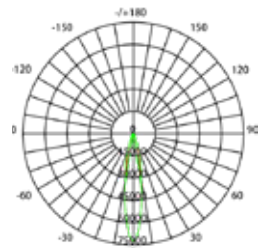
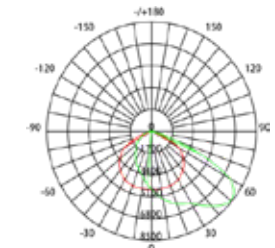
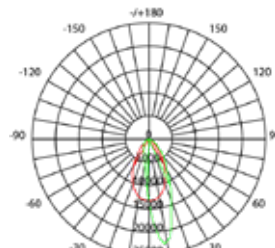
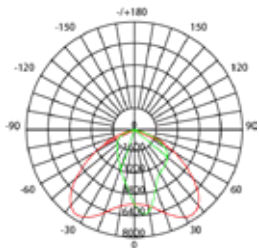

HIGH-POWER FLOODLIGHTS

ORDERING METHODOLOGY

PLI-PHXP	XXX WATTS	XX CCT	XX LENS TYPE
	50W	50 (5000K)	01 (F00801)
	100W	40 (4000K)	02 (F01601)
	150W	30 (3000K)	03 (F01602)
	200W	20 (2200K)	04 (F01603)
	300W		05 (F01604)
			06 (F01605)
			07 (F01606)

ACCESSORIES

- 42MM POLE MOUNT BRACKET
- 60MM POLE MOUNT BRACKET
- 76MM POLE MOUNT BRACKET
- WIRE GUARD
- ANTI CORROSION/MARINE GRADE VERSION
- PLIPHXP/PM42
- PLIPHXP/PM60
- PLIPHXP/PM76
- PLIPHXP/WG
- PLIPHXP/AC



Wire Guard



42mm/60mm/76mm Pole Mount Bracket



Phoenix Plus Anti Corrosion

