

HIGH-POWER FLOODLIGHTS



RAIDER SERIES

HIGH-POWER FLOODLIGHTS

RAIDER SERIES

The Raider Series LED floodlight is designed specifically for use in high mounting applications where large volumes of light are required. Featuring a modular design ranging from 200W - 1200W, the Raider offers unlimited adjustability for any large scale lighting application.



TYPICAL APPLICATIONS



Mining, MIA (Mining Infrastructure Area), Coal, Open Cuts, Metalliferous, Iron Ore, Industrial, Processing Plants, Materials Handling, Lithium Processing, Power Generation, Energy & Utilities, Water & Waste Water, Ports, Wharves & Waterways, Chemical & Processing, Ports & Wharves, Airports, Car Parks, General Area Lighting, Container Terminals

SPECIFICATIONS

Model	PLIRDR200	PLIRDR400	PLIRDR600	PLIRDR800	PLIRDR1200
Optical Characteristics					
Rated Wattage	200W	400W	600W	800W	1200W
Lumens	27000	54000	81000	108000	162000
System Efficacy	135Lm/W				
Colour Temperature CCT	5000K (4000K / 3000K)				
CRI (Ra)	>70				
Reported L70	>50,000 Hours				
Lens Optic Type	10° / 15° / 15° x 40° / 30° / 45° / 60°				
Electrical Characteristics					
Input	100-240VAC				
Frequency	50Hz				
Powerfactor	>0.92				
Total Harmonic Distortion	10%				
Environment					
IP Rating	IP65				
Impact Rating	IK08				
Operating Temperature	-30°C To 40°C				
Product Material and Mounting					
Option 1	Trunnion Mount Bracket				
Product Material	Aluminium Alloy				
Lens / Optics Material	PMMA				
Dimensions and Weights					
Product Dimensions	321*316*118	419*340*222	529*340*226	674*385*368	674*387*473
Product Weight	4.1KG	9.4KG	15.3KG	22.0KG	27.0KG
Packaging Dimensions	360*160*375	478*270*390	598*280*400	760*620*300	760*710*300
Gross Weight	4.7KG	10.6KG	16.8KG	26.0KG	30.0KG
Warranty and Certifications					
Warranty	5 Year Warranty				
Certifications	SAA / CE / RoHS				

HIGH-POWER FLOODLIGHTS

DIMENSIONS

200W/321*316*118

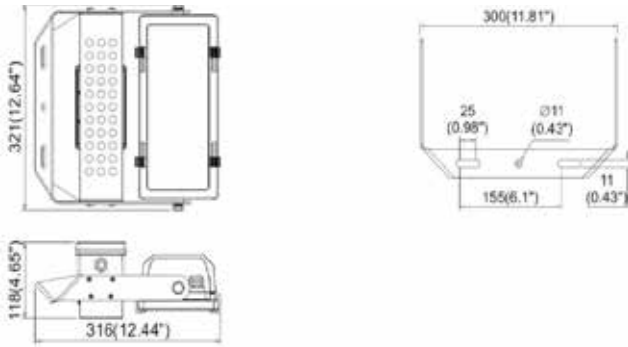

400W/419*340*222

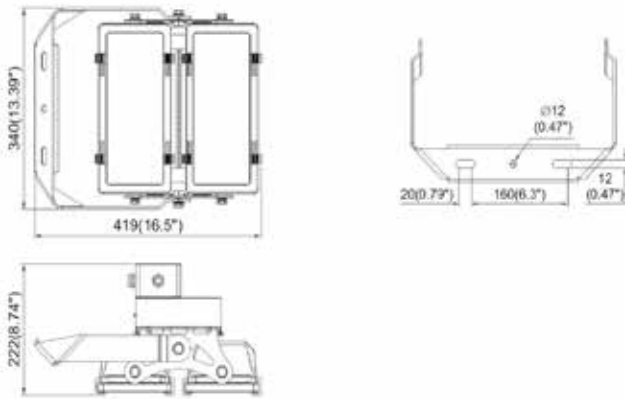

600W/529*340*226

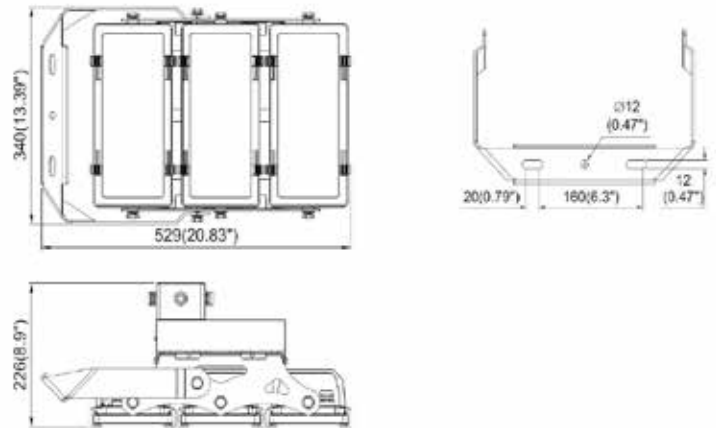

800W/674*385*368

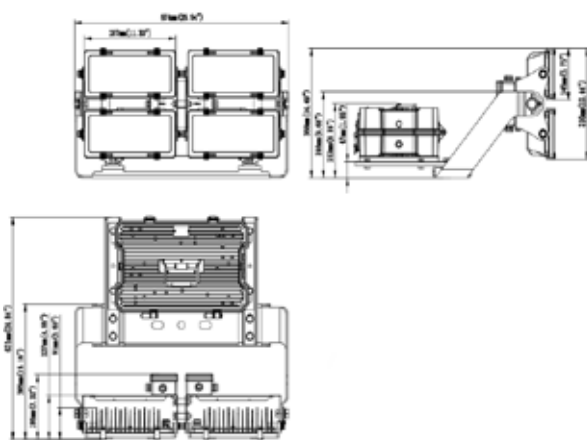

1200W/674*387*473

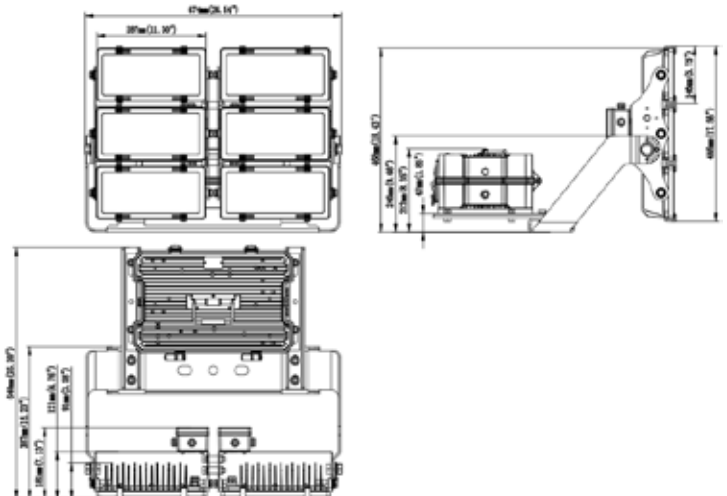

HIGH-POWER FLOODLIGHTS

ORDERING METHODOLOGY

PLI-RDR

**XXX
WATTS**

- 200W
- 400W
- 600W
- 800W
- 1200W

**XX
CCT**

- 50 (5000K)
- 40 (4000K)
- 30 (3000K)

**XX
LENS TYPE**

- 01 (F01601)
- 02 (F01602)
- 03 (F01603)
- 04 (F01604)
- 05 (F01605)
- 06 (F01606)

ACCESSORIES

TRUNNION MOUNT BRACKET
VISOR

PLIRDR/TM
PLIRDR/VIS



Optional Visor

PHOTOMETRIC DIAGRAMS

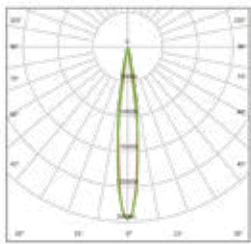

F06001/10°

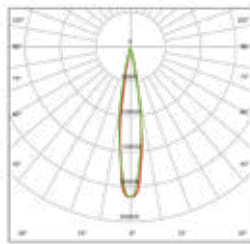

F06002/15°

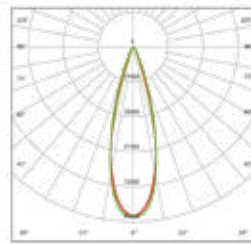

F06003/30°

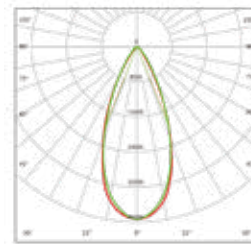

F06005/45°

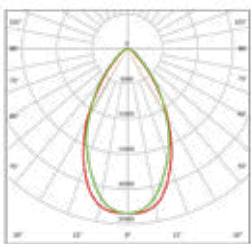

F06006/60°

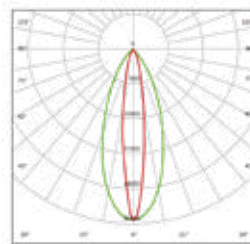

F06004/15° x 40°

